

# Series 6500 · Breakaway Panel

## MANUAL

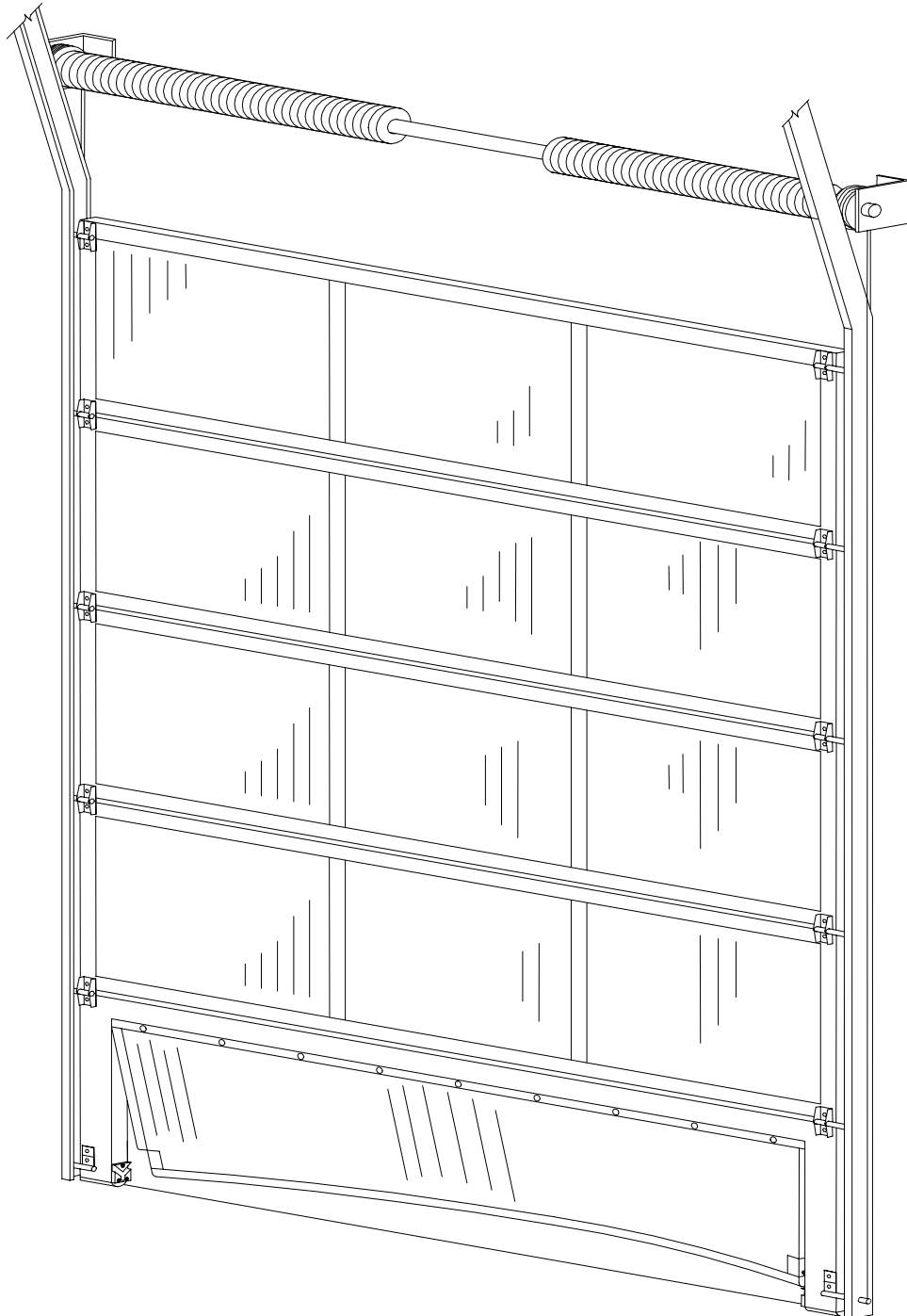

# Series 6500 · Breakaway Panel

## INSTALLATION LISTS

---

**THE FOLLOWING LISTS COVER BASIC INSTALLATION, NOT INCLUDING OPTIONS**

---

### Components List

No.		Qty.
1	Breakaway Panel	1

### Hardware Supplied List

No.		Qty.
1	Installation Instructions	1

### Recommended Tools List\*

Qty.	
1	Tape Measure
1	Level
1	Pencil or Marker
1	Square
1	Power Drill & Bits
1	Wrench Set
1	Ladder
2	Winding Bars
4	Vise-grips
*	Required tools may vary given existing door panel hardware

# Series 6500 · Breakaway Panel

## INSTALLATION INSTRUCTIONS

**READ ALL INSTRUCTIONS BEFORE INSTALLING DOOR. SUPER SEAL MFG. LTD. WILL NOT BE HELD RESPONSIBLE FOR IMPROPER INSTALLATION WHICH MAY RESULT IN PREMATURE PRODUCT WEAR, PRODUCT FAILURE, PROPERTY DAMAGE, OR PERSONAL INJURY. INSTALLATION MUST BE PERFORMED BY AN EXPERIENCED OVERHEAD DOOR INSTALLER USING STANDARD SAFETY PROCEDURES.**

### 1. Check Order

a. **Measure Breakaway Panel height, width, and thickness.**

- **Compare to Purchase Order.**
- **Compare** existing Bottom Panel **height, width** (Figure 1a), and **thickness** (Figure 1b) to Breakaway Panel.
  - \* Bottom Panel height does not include gasketing, if present.
  - \* Figures are a general reference and may not exactly match your door.
- **Compare Panel Hinge locations** on door panel to Galvanized Hinge Strip on Breakaway Panel (Figure 1c).
  - \* Make sure hinge locations match.

b. **Check Components List and Hardware Supplied List.** Make sure all components and hardware are present.

c. **Check Recommended Tools List.** Make sure all recommended tools are available.

d. **Inspect existing door and how it is used.**

- Check **mounting hardware**.
  - \* Hardware must fit Breakaway Panel and be in good condition.
- Check **cables** for fraying or damage.
- Check **track** for damage and secure mounting to wall.
- Check **rollers** for wear and proper movement.
- Check **spring** at top of door.
  - \* Spring must be in good condition and able to lift the Breakaway Panel.

e. **Replace worn or damaged hardware or door parts** before installing Breakaway Panel.

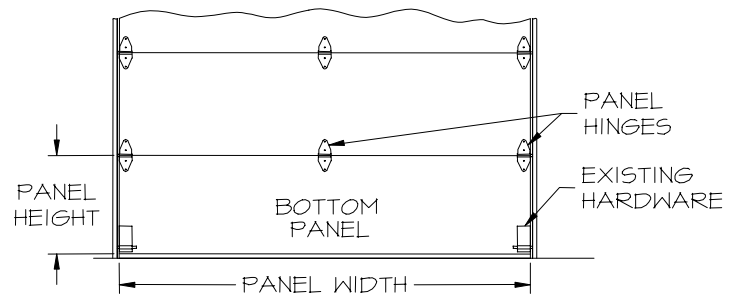

FIG. 1A

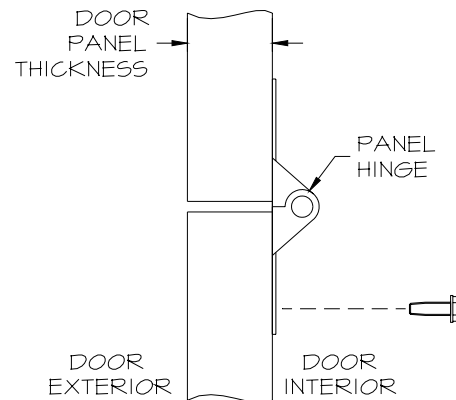

FIG. 1B

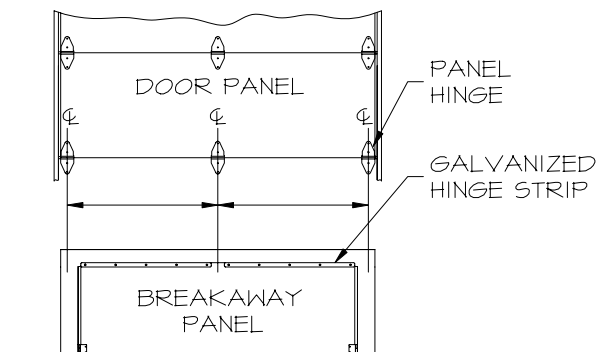

FIG. 1C

## 2. Secure & Prepare Door

- a. **Raise door** a few inches from the ground.
- b. **Secure door.**
  - **Fasten vise-grips to tracks** below rollers on both sides of door, between the second or third panel (Figure 2).
- c. **Remove tension from cables.**
  - **Insert a winding bar** into the spring fitting.
  - **Backwind spring** until tension is released (Figure 3).
    - \* Use alternating winding bars.
  - **Make sure cable is not under tension.**
  - **Secure winding bar** against wall.

**DANGER! ALL SPRINGS, CABLES, AND THE BRACKETS TO WHICH THEY ARE ATTACHED ARE UNDER HIGH TENSION. ALWAYS USE EXTREME CAUTION WHEN WORKING WITH THEM.**

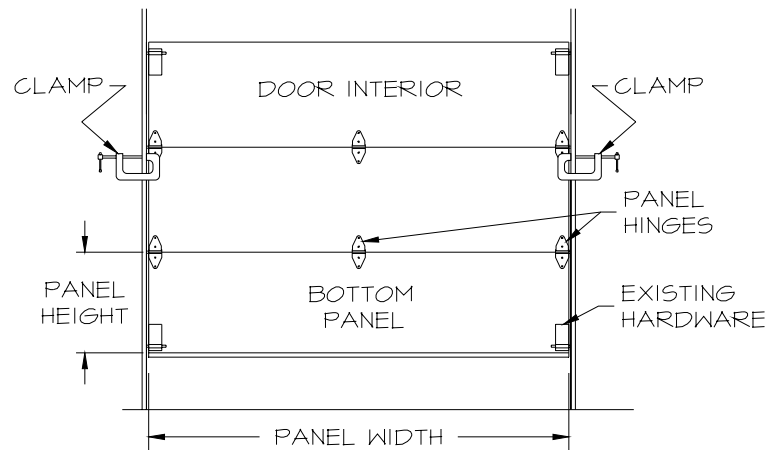

FIG. 2

## 3. Remove Lower Panel from Door

- a. **Remove hardware** from bottom of hinges on bottom panel.
  - Use a suitable method to hold bottom panel in place while removing hardware.
- b. **Remove Bottom Panel** from door.
- c. **Inspect hardware** and determine if it can be reused on new Breakaway Panel.
- d. **Remove any additional hardware** or hinges from bottom panel that will be remounted on Breakaway Panel.

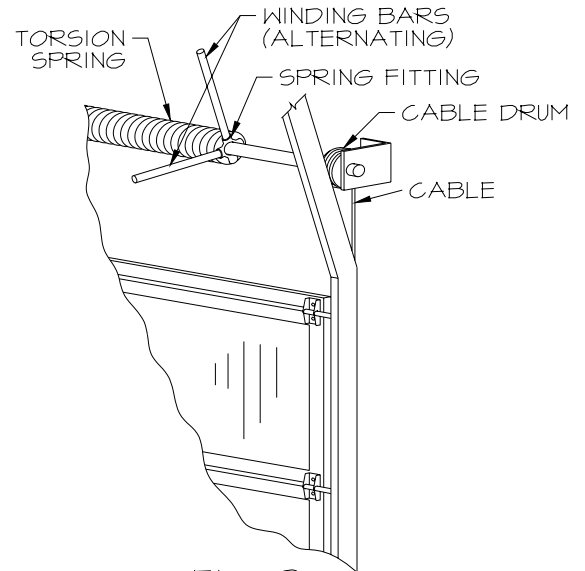

FIG. 3

## 4. Attach Breakaway Panel

- a. **Lift Breakaway Panel** into position.
  - Place side with **continuous Galvanized Hinge Strip** on exterior of door.
  - Use **suitable method** to hold panel in place.
  - **Align panel** with door on each side.
- b. **Match Panel Hinges** with breaks in Galvanized Hinge Strip on interior of Breakaway Panel.
  - **Shim Panel Hinges** on interior of door, if needed.
    - \* If **Breakaway Panel is the same thickness** as the door panel, do not shim (Figure 4a).
    - \* If **Breakaway Panel is thicker than door**, shim the top half of the Panel Hinge (Figure 4b).
    - \* If **Breakaway Panel is thinner than door**, shim the bottom half of the Panel Hinge (Figure 4c).
- c. **Mark and drill holes** in Breakaway Panel for panel hinges.
  - **Insert hardware** and tighten.
- d. **Reinstall hardware removed from original bottom panel**, if needed.
  - **Make sure** Panel Hinges, Rollers, and additional hardware do not interfere with the breakaway section of the Breakaway Panel.
- e. **Adjust tracks**, if needed.

## 5. Reapply Tension to Cables

- a. **Slowly and carefully reapply tension** to spring.
  - Use alternating winding bars.
  - Make sure cable rewinds properly on cable drums.
- b. **Adjust tension as required** for proper door operation.

**DANGER! ALL SPRINGS, CABLES, AND THE BRACKETS TO WHICH THEY ARE ATTACHED ARE UNDER HIGH TENSION. ALWAYS USE EXTREME CAUTION WHEN WORKING WITH THEM.**

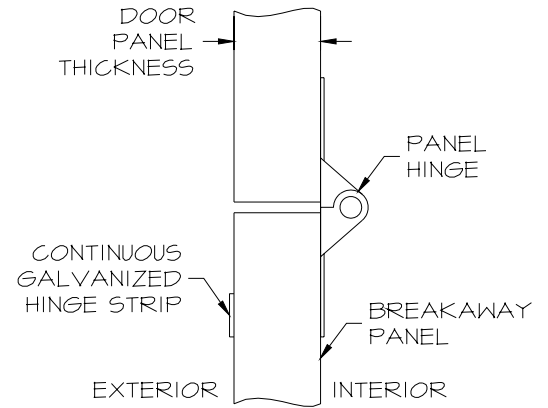

FIG. 4A

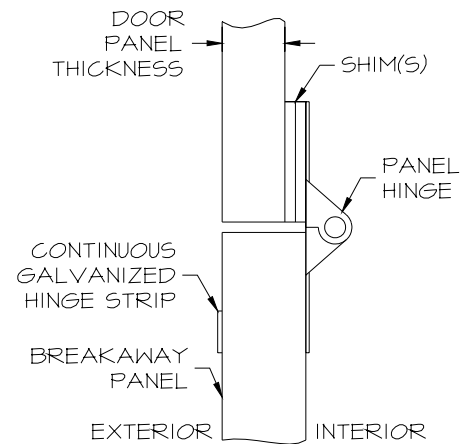

FIG. 4B

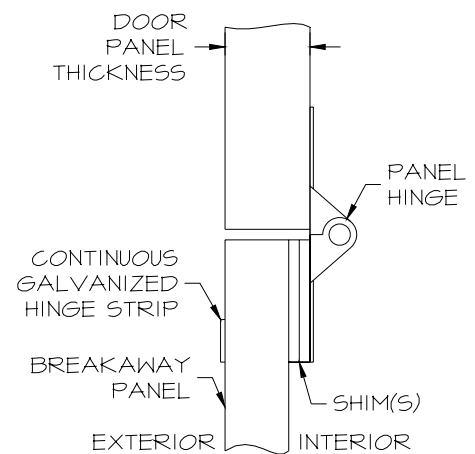

FIG. 4C

## 6. Test Door

- a. Lower door to floor.
  - Remove machinery or objects from bottom of door.
  - Remove vise-grips from tracks.
- b. Drill holes in track for Cane Bolts, if ordered. See Step 7.
- c. Test door.
  - Spring may need to be adjusted for proper door operation.
- d. Test Breakaway Panel.
  - Knock out Breakaway Panel (Figure 5a).
  - Grasp center of Breakaway Panel.
  - Lift panel so that Retaining Posts reach slots in Retaining Blocks (Figure 5b).
  - Release panel.
    - \* The Retaining Posts will slide into the Retaining Blocks, returning the Breakaway Panel to its normal position.

**NOTE: BREAKAWAY PANEL MUST BE UNLOCKED TO WORK PROPERLY.**

## 7. Cane Bolt (Option)

- a. Make sure door is fully closed.
- b. Mark hole location in track (Figure 6).
- c. Drill hole in track.
- d. Test Cane Bolt.
  - Slide Cane Bolt to unlock Breakaway Panel.
    - \* Make sure Cane Bolts do not interfere with Breakaway Panel.
  - Slide Cane Bolt back to lock Breakaway Panel.
- e. Repeat for other side.
- f. Return to Step 6c to test door.

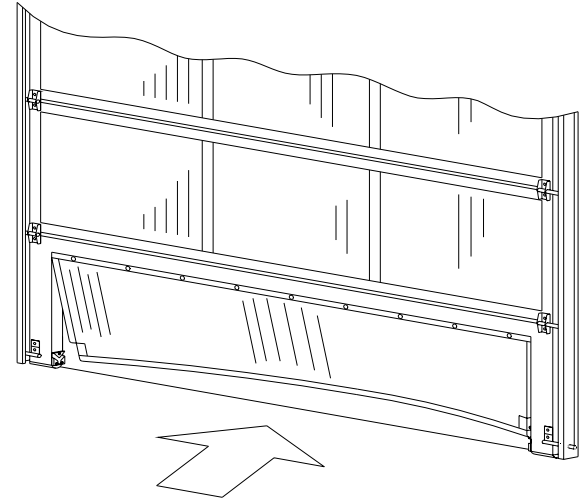

FIG. 5A

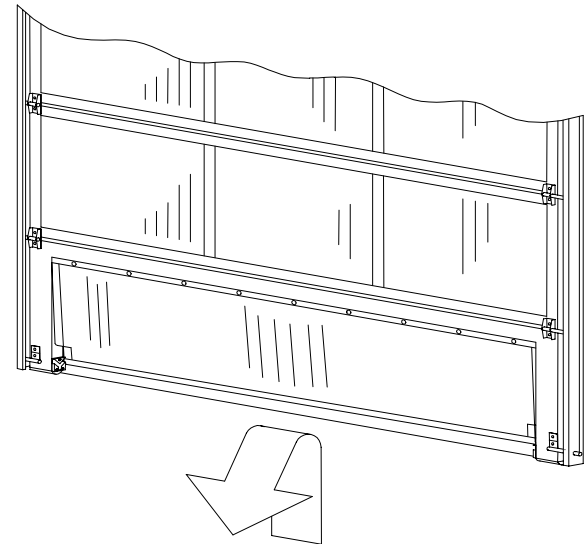

FIG. 5B

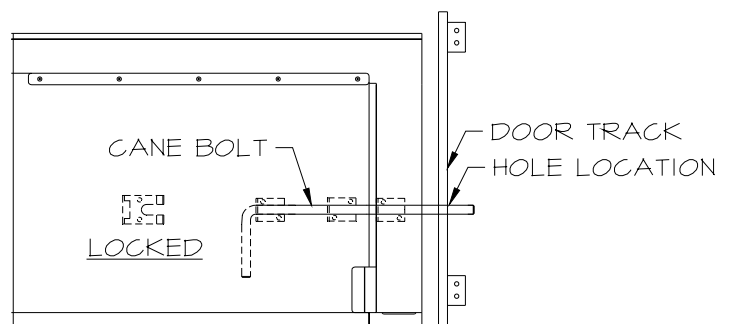

FIG. 6